



INVITATION FOR SEALED BID

Bid 01-501

Description: ALUMINUM SIGN BLANKS

Department: PUBLIC WORKS

NIGP Commodity Code(s): 550-58-00-00-000-0

Total pages including this page is 14

NOTE: FAXING OF BID WILL NOT BE ACCEPTED

Important Instruction – Read Carefully:

**If you have obtained these bid specifications from either of:
City of Tulsa's Fax-on-Demand (918-596-1171) or
City of Tulsa's Web-site : www.cityoftulsapurchasing.org**

You must notify the buyer Darlene Donica of your intent to bid by e-mail ddonica@ci.tulsa.ok.us in order to receive addenda. The buyer will always acknowledge your e-mail for your records. All addenda will be posted on fax-on-demand and the web-site.

TABLE OF CONTENTS

Pay special attention to those pages with a reference to the following notes:

Note #1: Signature of authorized agent required

Note #2: Signature of an authorized agent and notarized required

Table of Contents		2
Invitation for Sealed Bid	(Note #1)	3
General Terms and Conditions		4
Interest Affidavit	(Note #2)	5
Bidder Affidavit	(Note #2)	6
Contractor Information Sheet		7
Summary Price Sheet		8-9
Specifications		10-14

Your bid response should follow the same format listed above plus any additional format requested in the body of the bid invitation.

**INVITATION FOR SEALED BIDS
TO
City of Tulsa**

200 CIVIC CENTER, ROOM 109, TULSA, OKLAHOMA 74103

Bid number and date of bid opening must appear on the lower
left outside corner of bid envelopes and all related containers.

DATE OF OPENING: AUGUST 16, 2001

BID NUMBER: 01-501

**BID MUST BE IN THE CITY CLERK'S OFFICE AT THE ABOVE ADDRESS BY 5:00 P.M. THE DAY
PRECEDING THE "DATE OF OPENING" SHOWN ABOVE.**

BIDS WILL BE OPENED AT 8:30 A.M. IN THE CITY COUNCIL ROOM ON THE DAY SPECIFIED UNDER "DATE OF OPENING."

PUBLISHED IN THE TULSA DAILY COMMERCE AND LEGAL NEWS: July 30, 31, August 1, 2, 3, 2001

Bid must be accompanied by bidder's bond, cashier's check or certified check in the amount of: NONE

PLEASE READ TERMS AND CONDITIONS ON THE NEXT PAGE BEFORE COMPLETING BID DOCUMENTS

***** **THE FOLLOWING SECTION MUST BE COMPLETED BY BIDDER** *****

Delivery will be made in not more than _____ days after receipt of order.

Payment terms _____ % _____ days.

City of Tulsa may increase quantity of order at the unit price bid for _____ days. (Bidder to Specify Days) I have examined the terms and specifications and the instructions to bidders herein and agree, provided I am awarded a contract, to provide the above described items for the sum shown in accordance with the terms and specifications stated herein. All deviations are in writing and attached hereto.

Enclosed is a BID BOND ; CASHIER'S CHECK; Certified Check in the amount of \$ _____, which I agree the City of Tulsa may retain as liquidated damages in the event of my failure to comply with the terms of this bid.

MUST BE SIGNED BY AUTHORIZED AGENT TO BE VALID

FIRM NAME _____

by

(Signature)

STREET _____

TITLE

CITY STATE _____ ZIP CODE _____ PHONE NUMBER _____ DATE _____

GENERAL TERMS AND CONDITIONS OF BIDS

THESE ITEMS APPLY TO AND BECOME A PART OF THE BID.

NO EXCEPTIONS TO THESE TERMS & CONDITIONS WILL BE CONSIDERED.

1. **BIDS MUST BE SUBMITTED ON THIS FORM ONLY INCLUDING A SIGNATURE OF AN AUTHORIZED AGENT.** Each bid shall be placed in a separate envelope. Be sure envelope is completely and properly identified and sealed, showing the bid number and date in the lower left hand corner. Bids must be time stamped in the office of the City Clerk by 5:00 P.M. on the day before date of opening.
2. No bidder may withdraw his proposal for a period of thirty (30) days after the date and hour set for the opening of bids.
3. All prices shall be quoted F.O.B. Tulsa, Oklahoma, and delivery to City of Tulsa location shall be without additional charge.
4. The bidder shall attach the manufacturer's name of the equipment or material to be furnished, type, model numbers, manufacturer's descriptive bulletins and specifications. All guarantees and warranties should be clearly stated. This data shall be in sufficient detail to describe accurately the equipment or material to be furnished. Manufacturer's specifications, in respect to the successful bidder, shall be considered as part of his contract with the City of Tulsa.
5. The bidder shall show in the proposal both the unit prices and total amount, where required, of each item listed. In the event of error or discrepancy in the mathematics, the unit prices shall prevail.
6. Any exceptions or deviations from written specifications shall be shown in writing and attached to the bid form.
7. Each bidder agrees to comply with the terms of Title 5, Chapter 1, of Tulsa, Oklahoma Charter and revised ordinances relating to equal employment opportunity.
8. **THE ENCLOSED FORMS REGARDING NON-COLLUSION AND FINANCIAL INTEREST MUST BE SIGNED, NOTARIZED, AND RETURNED WITH THE BID.**
9. The City of Tulsa reserves the right to reject any and all bids, to waive any technicalities in the bidding, and to award each item to different bidders or all items to a single bidder.
10. All bids must be accompanied by bidders bond, cash, certified or cashier's check in the amount shown on the face of the bid form. This amount shall be retained by the City of Tulsa as liquidated damages in the event the successful bidder (or bidders) fails to execute a contract, if required. The bidder agrees that said amount is presumed to be the damages sustained by the City due to the impracticability and extreme difficulty in fixing the actual damages. The office of the City Clerk will return the bid deposits to the unsuccessful bidders, after a contract has been awarded or all bids have been rejected.
11. In the event cash discounts are offered by the bidder, the discount date shall begin with the date of invoice, the date of receipt of all material covered by the purchase order, or the date of receipt by the City of Tulsa of the original copy of the purchase order with properly executed Affidavit of Claimant, whichever is the later date.
12. Direct purchase of certain items of equipment or material by the City of Tulsa are exempt from Federal Excise Tax and Oklahoma Sales Tax. In such cases the bidder shall quote prices which do not include Federal Excise Tax and Oklahoma Sales Tax. The City of Tulsa will furnish executed exemption certificates upon presentation by the bidder at the time of purchase.
13. Bid must show number of days required for delivery under normal conditions. Failure to state delivery time obligates bidder to complete delivery in fourteen (14) calendar days. Unrealistically short or long delivery promises may cause bid to be disregarded. Contractor must keep Purchasing Department advised at all times of status of order. Default in promised delivery or failure to meet specifications authorizes the Purchasing Agent to purchase supplies elsewhere and charge full increase of cost and handling to defaulting contractor. Consistent failure to meet delivery promises without valid reason may cause removal from bid list.
14. Bidder agrees to defend and save City of Tulsa from and against all demands, claims, suits, costs, expenses, damages and judgments based upon infringement of any patent relating to goods specified in this order or the ordinary use or operation of such goods by City or use or operation of such goods in accordance with bidders direction.
15. If the bid requires a written contract, the successful bidder shall execute a written contract with the City of Tulsa and return the required bonds and insurance certificates within ten (10) days after submission of contracts to said bidder by the City.

BIDDER AFFIDAVIT - TITLE 74 O.S. (1974 SUPP.) 85.22-85.25

STATE OF _____ COUNTY OF _____

_____, of lawful age, being first duly sworn on oath says
Authorized Agent

1. (s)he is the duly authorized agent of _____, the bidder submitting the competitive bid which is attached to this statement, for the purpose of certifying the facts pertaining to the existence of collusion among bidders and between bidders and municipal officials or employees, as well as facts pertaining to the giving or offering of things of value to government personnel in return for special consideration in the letting of any contract pursuant to the bid to which this statement is attached.
2. (s)he is fully aware of the facts and circumstances surrounding the making of the bid to which this statement is attached and has been personally and directly involved in the proceedings leading to the submission of such bid; and
3. neither the bidder nor anyone subject to the bidder's direction or control has been a party;
 - a. to any collusion among bidders in restraint of freedom of competition by agreement to bid at a fixed price or to refrain from bidding,
 - b. to any collusion with any municipal official or employee as to quantity, quality or price in the prospective contract, or as to any other terms of such prospective contract, nor
 - c. in any discussions between bidders and any municipal official concerning exchange of money or other thing of value for special consideration in the letting of a contract.

SIGNATURE OF AUTHORIZED AGENT

Subscribed and sworn to before me this _____ day of _____, 19_____.

Signature of Notary Public

MY COMMISSION EXPIRES

The Bidder Affidavit must be completed, signed by an authorized agent, and notarized.

CONTRACTOR/BIDDER INFORMATION SHEET
To be completed by all Bidders
For Contracts with the City of Tulsa
(Please print or type)

Project No. or Description _____

Full Name of Bidder _____

Legal Identity
(Corporation, Partnership,
Individual, etc.) _____

Address _____

Telephone No. _____

FAX No. _____

Taxpayer Identification Number _____

Contact Person _____

Phone No. _____

Fax No. _____

E-mail address _____

Webpage Address _____

Price Sheet Summary

Vendor Name: _____ Signature: _____
Date: _____

You will be able to obtain a copy of the Bid Summary on the City of Tulsa's Purchase-Net Fax-on-Demand and Website shortly after bid opening.

BID 01-501

<u>Item #</u>	<u>Qty</u>	<u>Description</u>	<u>Unit Cost</u>	<u>Total Cost</u>
1.	1000	12" x 6" (1-6) Rectangle, 4" between holes, .063 thick	\$ _____	\$ _____
2.	1000	12" x 18" (1-4) Rectangle, 16" between holes, .063 thick	\$ _____	\$ _____
3.	600	18" x 18" (C-3) Square, 15" between holes, .080 thick	\$ _____	\$ _____
4.	800	18" x 24" (1-2) Rectangle, 18" between holes, .080 thick	\$ _____	\$ _____
5.	200	24" x 24" (C-2) Square, 18" between holes, .080 thick	\$ _____	\$ _____
6.	200	30" x 30" (C-1) Square, 18" between holes, .080 thick	\$ _____	\$ _____
7.	500	30" x 30" (E-2) Diamond, 18" between holes, .080 thick	\$ _____	\$ _____
8.	200	30" x 30" (B-2) Octagon, 18" between holes, .080 thick	\$ _____	\$ _____
9.	50	24" x 24" (H-1) Rectangle, 18" between holes, .080 thick	\$ _____	\$ _____

10.	10	48" x 144" (k) Sheets, No holes and no corner Radii, .080 thick	\$ _____	\$ _____
11.	500	6" x 24" (J-6) Extruded, No corner radii	\$ _____	\$ _____
12.	500	6" x 30" (J-5) Extruded No corner radii	\$ _____	\$ _____
13.	300	9" x 30" (J-3) Extruded, No corner radii	\$ _____	\$ _____
14.	600	24" x 30" (H-2) Rectangle, 18" between holes, 080 thick	\$ _____	\$ _____

GRAND TOTAL: \$ _____

For more information please contact: Elmer Morse @ 918-596-9765

**BID 01-501
ALUMINUM SIGN BLANKS
PUBLIC WORKS DEPARTMENT**

INTENT:

It is the intent of this bid to secure, on a competitive basis, a source of supply for furnishing **Aluminum Sign Blanks** for the City of Tulsa, Public Works Department.

GENERAL:

Inasmuch as some designs of equipment vary among different manufacturers, the City may accept bids on equipment with minor deviations to the written specifications. Generally, a minor deviation is defined as a deviation which does not: (A) Materially affect the ability of the product to achieve or accomplish a necessary function or task in the manner required by the specifications; (B) Compromise the safety of the user thereof; and, (C) Produce higher latent or patent costs to the City in any of a multiplicity of ways. The City of Tulsa specifically reserves the right to make the final judgement concerning what is or is not a minor deviation and to award to the bidder(s) whose bid(s) best suit the City's need for the product being purchased.

ALTERING BIDS:

Bids cannot be altered or amended after submission deadline. Any interlineation, alteration, or erasure made before opening time and date must be initialed by the signer of the bid, guaranteeing authenticity. Bids must be submitted in ink or typewritten. Penciling will not be accepted.

PRICING:

Bid prices, unless otherwise specified, must be net, including transportation and handling charges fully prepaid by vendor to destination and subject only to cash discount for prompt payment of invoice.

DESCRIPTIVE LITERATURE, BROCHURES, SPECIFICATIONS SHEETS:

Bidders must provide descriptive literature, brochures and or specification sheets on product bidding. This information is to be part of your bid and included with your bid package. Failure to comply may result in rejection of your bid.

DELIVERY:

Delivery time must be stated in days in the appropriate spaces of the cover sheet. Indefinite terms such as “promptly”, “without delay”, etc., will not be given consideration. Failure to indicate delivery time shall be cause for rejection of the bid.

BIDDER AFFIDAVITS:

Each bidder shall accompany his bid with a fully executed and notarized copy of the attached Non-Collusion Affidavit and the Interest Affidavit. Failure to do so shall be cause for rejection of the bid.

ADDENDA AND INTERPRETATIONS:

If it becomes necessary to revise any part of this bid, a written addendum will be provided to all the bidders. The City of Tulsa is not bound by any oral representations, clarifications, or changes made in the written specifications by City of Tulsa employees unless such clarification or change is provided to bidders in written addendum form from the Purchasing Division.

AWARD OF BID:

The bid shall be awarded to the firm whose proposal is responsive to the bid and is most advantageous to the City, considering the factors identified in the bid and Section 406E of Title 6, The Purchasing Ordinance set forth below:

406E. AWARD OF CONTRACT

1. Authority in the Mayor. The Mayor shall have the authority to award Contracts within the purview of this chapter.
2. Lowest Secure Bidder. Contracts shall be awarded to the lowest secure Bidder meeting specifications. Bid Specifications may include a point System for evaluating the lowest secure bid. In determining “lowest Secure bidder”, in addition to price, the following factors shall be considered:
 - a. the ability, capacity and skill of the bidder to perform the contract Or provide the service required;
 - b. whether the bidder can perform the contract or provide the service promptly or within the time specified, without delay or interference;
 - c. the character, integrity, reputation, judgment, experience and efficiency of the bidder;
 - d. the quality of performance of previous contracts or services;
 - e. the previous and existing compliance by the bidder with laws and

ordinances relating to the contract or service;

- f. the sufficiency of the financial resources and ability of the bidder to perform the contract or provide the service;
- g. the quality, availability and adaptability of the supplies or contractual services to the particular use required;
- h. the ability of the bidder to provide future maintenance and **service for the use of the subject of the contract;**
- i. **where an earlier delivery date would be of great benefit to the requisitioning agency, the date and terms of delivery may be considered in the bid award, and**
- j. **the number and scope of conditions attached to the bid.**
- k. **If a point system has been utilized in the bid specifications, the number of points earned by the bidder.**

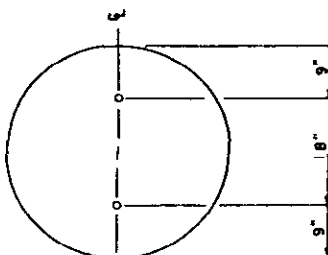
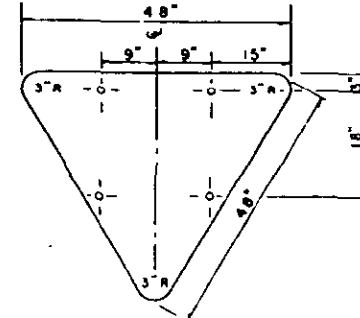
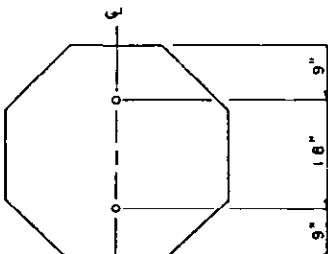
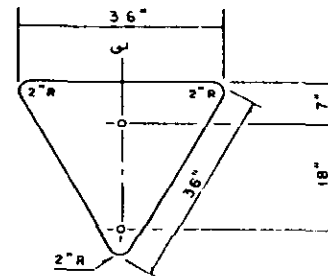
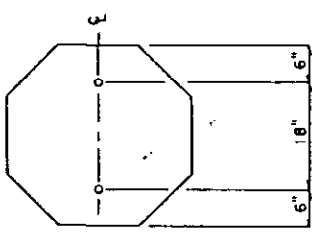
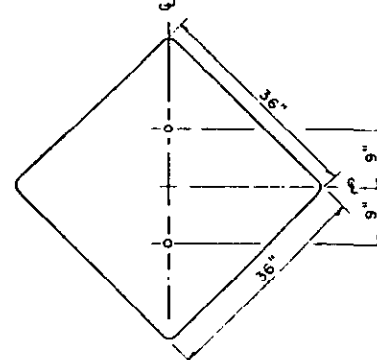
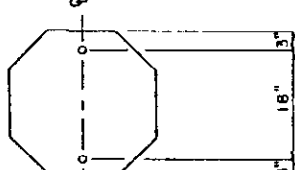
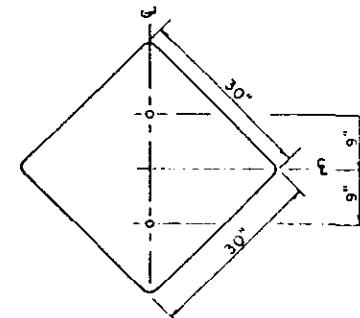
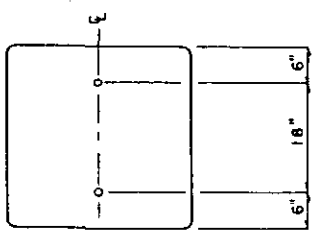
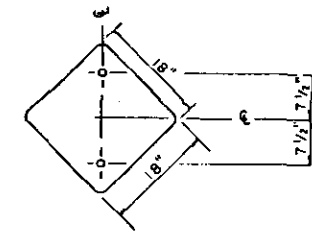
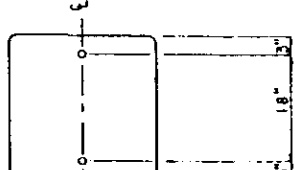
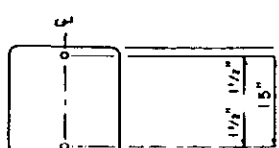
Size	Gauge	Hole Location	Size	Gauge	Hole Location	Size
36" Dia	.100		48" x 48"	.100		30" x 24"
36" x 36"	.100		36" x 35"	.100		24" x 24"
30" x 30"	.080		36" x 35"	.080		30" x 30"
24" x 24"	.080		30" x 30"	.080		48" x 24"
20" x 30"	.080		18" x 18"	.080		30" x 24"
24" x 24"	.080					24" x 18"
8" x 18"	.080					36" x 12"
						24" x 12"
						18" x 12"

Note: All Sign Blanks Shall Be Fabricated Of 5052-H38 As Follows. They Shall Have 3/8" Diameter Bolt Holes Located As Shown And 1 1/2" Corner Radii Except As Noted. Shearing Tolerance Shall Be 1/16" ±. All Shearing And Punching Burrs Removed. All Holes To Be On Axis Located Along The Center Line Of The Blank Parallel To The Vertical Sides Unless Indicated Otherwise.

