



Invitation For Bid (IFB)
#TAC528D Backhoes
Issued: October 20, 2011
City of Tulsa

City of Tulsa,
Oklahoma
Page 1 of 46

ADDENDUM

No.	Date	Description
2	11/7/2011	1. IFB put on temporary hold
1	10-25-2011	These specifications are for both 2 Wheel Drive and 4 Wheel Drive backhoes. The changes made as part of this addendum did not change the technical specification. The changes were to correct format and correct minor errors.
Your IFB response must be submitted using the latest IFB.		

18498





Invitation For Bid (IFB)
#TAC528D Backhoes
Issued: October 20, 2011
City of Tulsa

City of Tulsa,
Oklahoma
Page 2 of 46

NOTICE is hereby given that the CITY OF TULSA, OKLAHOMA will receive sealed Bids for the following:

BID # **TAC528D**

DESCRIPTION: **Backhoes** (Commodity Code(s): 760-02, 760-03, 760-04)

You are invited to submit a Bid to supply the Goods and/or Services specified above. Invitations for Bid (IFB) will be posted on the City's website at www.cityoftulsapurchasing.org or a hardcopy may be obtained at:

City of Tulsa-Purchasing Division
175 East 2nd Street, Suite 865
Tulsa Oklahoma 74103

Bids must be received no later than 5:00 PM (CST) on ON HOLD, and delivered to:

City Clerk's Office
175 East 2nd Street, Suite 260
Tulsa Oklahoma 74103

Bids must be sealed and either mailed or delivered. No faxed or emailed Bids will be considered. Bids received after the stated date and time **will not be accepted and will be returned to the Bidder unopened.**

The Bid Packet consists of (1) this Notice of Invitation for Bid, (2) the Summary Sheet, (3) Form #1, (4) Form #2, (5) Form #3, (6) Form #4, (7) Form #5, (8) Form #6, (9) the Instructions, Terms and Conditions for Bidders, (10) Special Requirements, (11) Technical Specifications and (12) Exhibit A.

Use this checklist to ensure you have properly read and completed all Forms.

- Notice of Invitation for Bid
- Summary Sheet
- Form #1: Bidder Information Sheet. Must be completed.
- Form #2: Purchase Agreement. **Complete legal name in first paragraph and Notice provision in Section 17.i. Original signature required.**
- Form #3: Interest Affidavit. Original signature and notarization required.
- Form #4: Non-Collusion Affidavit. Original signature and notarization required.
- Form #5: Affidavit of Claimant. Original signature and notarization required.
- Form #6: Acknowledgment of Receipt of Addenda/Amendments. Must be completed and signed.
- Instructions, Terms and Conditions for Bidders
- Special Requirements (Offer Period; Insurance and Bonding; References)
- Technical Specifications
- Exhibit A: Bid Form including Delivery and Pricing. This is your Bid. It must be completed or your Bid will be rejected.

IMPORTANT NOTE: Write the Bid Number, Bid Description (as listed above), and Bid Opening Date on the lower left corner of the outside of your Bid envelope. You must return the entire completed Bid Packet.

SUMMARY SHEET



Invitation For Bid (IFB)
#TAC528D Backhoes
Issued: October 20, 2011
City of Tulsa

City of Tulsa,
Oklahoma
Page 3 of 46

Project Buyer

If you have any questions or need additional information, contact the assigned Project Buyer:

Bill Youngblood

byoungblood@cityoftulsa.org

Include **IFB #TAC528D** on the subject line

Bidder's Notice of Intent to Submit a Bid

Email the Project Buyer indicating your intent to Bid. Include **IFB #TAC528D** on the subject line of the email. You will receive an email response verifying your notice of intent to bid was received. This same procedure should be followed to request clarification, in writing, of any point in the IFB.

Bidders are encouraged to contact the Project Buyer by email if there is anything in these specifications that prevents you from submitting a Bid, or completing the Bid Packet. Questions and concerns must be received no later than seven (7) days prior to the Bid Packet due date.

Issuing of Addenda

If you received the notice of this IFB from the City as a result of being registered to sell the commodity code(s) on this Bid, you should also receive notice of any addenda issued. If you are not registered with the City to sell the commodities listed herein, you must register as a supplier on the City of Tulsa Purchasing website (www.cityoftulsapurchasing.org) to receive notice of any addenda, or to receive notice of any future IFBs.

Pre-Bid Conference

If a pre-Bid conference will be held for this IFB, information on that conference will be inserted below:

Date NA Time

Location

Attendance at the Pre-Bid Conference is required to submit a Bid; however Bidders may make arrangements to attend via teleconference in some cases (contact the Project Buyer for details).

Attendance is not required to submit a Bid.

Bid Packet Submission

The City requires two completed Bid packets: 1 Original and 1 Copy. Each must be clearly labeled on the front sheet indicating "Original" or "Copy". If a copy on electronic media is also required, the line below will be checked.

Electronic Copy also required.

Responses to this Invitation for Bid must be made on the forms listed on page 1. The entire completed Bid Packet must be returned or your Bid may be rejected. Do not take exception to any portion of this Bid Packet. Do not make any entries except where required. Do not insert any other documents into the Bid Packet.

Bid Opening

All Bid openings are public and take place at 8:30 a.m. Thursday, the day after Bids are due. The Bid openings are held in the City of Tulsa Council Meeting Room, 175 East 2nd Street, 2nd Floor, Tulsa, Oklahoma.



**Invitation For Bid (IFB)
#TAC528D Backhoes
Issued: October 20, 2011
City of Tulsa**

**City of Tulsa,
Oklahoma**
Page 5 of 46

**FORM #2 (Page 1 of 4)
PURCHASE AGREEMENT**

INSTRUCTIONS: This document **must** be properly signed and returned or your Bid will be **rejected**. This form constitutes your offer and if accepted by the City of Tulsa will constitute the Purchase Agreement under which you are obligated to perform. Your signature on this document indicates you have read and understand these terms and agree to be bound by them.

THIS PURCHASE AGREEMENT is between the CITY OF TULSA, OKLAHOMA, a municipal corporation, 175 East 2nd Street, Tulsa, Oklahoma, 74103-3827 (the "City") and _____ (Bidder's company name as reflected on its organizational documents, filed with the state in which bidder is organized; not simply a DBA) (the "Seller").

WITNESSETH:

WHEREAS, the City has approved certain specifications and advertised for or solicited Bids on the following goods or services:

Bid #TAC528D Backhoes

(the "Goods and/or Services"); and

WHEREAS, Seller desires to provide such Goods and/or Services to City, acknowledges that this document constitutes Seller's offer to provide the Goods and/or Services specified below, and further acknowledges that if executed by the City's Mayor, this document will become the Purchase Agreement for such Goods and/or Services.

NOW, THEREFORE, for and in consideration of the terms, covenants and conditions hereinafter set forth, the parties hereto agree as follows:

- Documents Comprising the Agreement.** The Bid Packet includes the Notice of Invitation to Bid, the Summary Sheet, Form #1, Form #2, Form #3, Form #4, Form #5, Form #6, the Instructions, Terms and Conditions for Bidders, the Special Requirements, the Technical Specifications, Exhibit A and any addenda or amendments to the Bid Packet. The Bid Packet is incorporated herein by this reference. In the event of conflicting or ambiguous language between this Purchase Agreement and any of the other Bid Packet documents, the parties shall be governed first according to this Purchase Agreement and second according to the remainder of the documents included in the Bid Packet. Seller may submit as part of its Bid additional materials or information to support the Bid. Additional materials or information submitted by Seller which are not ambiguous and which do not conflict with this Purchase Agreement or the other Bid Packet documents are incorporated herein by this reference.
- Purchase and Sale.** Seller agrees to sell City the Goods and/or Services for the price and upon the delivery terms set forth in Exhibit A hereto. City agrees to pay Seller the price as set forth in Exhibit A based on (a) the quantity actually purchased in the case of goods or services priced by unit, or (b) the total price for a stated quantity of goods or services, upon (i) delivery of the Goods and/or Services to the City, (ii) the City's Acceptance thereof, and (iii) Seller's submission and City's approval of a verified claim for the amount due. City shall not pay any late charges or fees.
- Irrevocable Offer.** Seller understands and acknowledges that its signature on this Agreement constitutes an irrevocable offer to provide the Goods and/or Services. There is no contract unless and until City's Mayor/Mayor Pro Tem executes this Agreement accepting Seller's Bid. No City officer, employee or agent except the Mayor (or Mayor Pro Tem) has the authority to award contracts or legally obligate the City to any contract. Seller shall not provide any Goods and/or Services to City pursuant to this Agreement before this Agreement is executed by City. If Seller provides any Goods and/or Services to City pursuant to this Agreement before this Agreement is executed by City, such Goods and/or Services are provided at Seller's risk and City shall have no obligation to pay for any such Goods and/or Services.
- Term.** The term of this Agreement shall be effective commencing on the date of execution of this Agreement by the Mayor/Mayor Pro Tem of the City of Tulsa and terminating one year from that date, **or shall be effective on [month][day], 20__ and continuing to [month][day], 20__ at the discretion of City.** City in its sole discretion may offer Seller an opportunity to renew this Agreement for an additional two (2) one (1) year term(s). Seller understands and acknowledges that any future contracts or renewals are neither automatic nor implied by this Agreement. The continuing purchase by City of the Goods and/or Services set forth in this Agreement is subject to City's needs and to City's annual appropriation of sufficient funds in City's fiscal year (July 1st to June 30th) in which such Goods and/or Services are purchased. In the event City does not appropriate or budget sufficient funds to perform this Agreement, this Agreement shall be null and void without further action by City.
- Warranties.** Seller shall assure that the Goods and/or Services purchased hereunder are covered by all available and applicable manufacturers' warranties for such Goods and/or Services. Seller expressly agrees that it will be responsible for performing all warranty obligations set forth in the Special Requirements for the Goods and/or Services covered in this Agreement. Seller also warrants that the Goods and/or Services will conform to the Technical Specifications and Special Requirements, and further warrants that the Goods and/or Services shall be of good materials and workmanship and free from defects for either a minimum of one (1) year from the date of Acceptance or installation by City, whichever is later, or as **specified in the Special Requirements**, whichever is later. In no event shall Seller be allowed to disclaim or otherwise limit the express warranties set forth herein.
- Warranty Remedies.** City shall notify Seller if any of the Goods and/or Services fails to meet the warranties set forth above, and Seller shall promptly correct, repair or replace such Goods and/or Services at Seller's sole expense. Notwithstanding the foregoing, if such Goods and/or Services shall be determined by City to be defective or non-conforming within the first thirty (30) days after the date of Acceptance by City, then City at its option shall be entitled to a complete refund of the purchase price and, in the case of Goods, shall promptly return such Goods to Seller. Seller shall pay all expenses related to the return of such Goods to Seller.



**Invitation For Bid (IFB)
#TAC528D Backhoes
Issued: October 20, 2011
City of Tulsa**

**City of Tulsa,
Oklahoma**
Page 6 of 46

**FORM #2 (Page 2 of 4)
PURCHASE AGREEMENT**

7. **Seller Bears Risk.** The risk of loss or damage shall be borne by Seller at all times until the Acceptance of the Goods or Services by City.
8. **No Indemnification by City.** Seller understands and acknowledges that City is a municipal corporation that is funded by its taxpayers to operate for the benefit of its citizens. Accordingly, and pursuant to Oklahoma law, City shall not indemnify nor hold Seller harmless for loss, damage, expense or liability arising from or related to this Agreement, including any attorneys' fees and costs. In addition, Seller shall not limit its liability to City for actual loss or direct damages for any claim based on a material breach of this Agreement and the documents incorporated herein. City reserves the right to pursue all legal and equitable remedies to which it may be entitled.
9. **Indemnification by Seller.** Seller agrees to indemnify, defend, and save harmless City and its officers, employees and agents from all suits and actions of any nature brought against them due to the use of patented appliances, products or processes provided by Seller hereunder. Seller shall pay all royalties and charges incident to such patents.
10. **No Insurance by City.** If City is leasing Goods herein, City shall not be required to obtain insurance for Seller's property. Seller shall be solely responsible for any insurance it deems necessary. City is self-insured for its own negligence, subject to the limits of the Governmental Tort Claims Act (51 O.S. § 151 et seq.).
11. **No Confidentiality.** Seller understands and acknowledges that City is subject to the Oklahoma Open Records Act (51 O.S. §24A.1 et seq.) and therefore cannot assure the confidentiality of contract terms or other information provided by Seller pursuant to this Agreement that would be inconsistent with City's compliance with its statutory requirements thereunder.
12. **Non-Responsive Bids.** Seller understands and acknowledges that if it adds terms and conditions to its Bid that are different from the terms set forth herein that its Bid may be rejected as non-responsive. Furthermore, if City accepts Seller's Bid and awards a contract to Seller based on such Bid, City shall not be bound to any exceptions, changes or additions made by Seller, and any terms and conditions added by Seller which are not expressly agreed to by City in writing will be void and of no force and effect and the parties will be governed according to the document precedence set forth in Section 1 above.
13. **Compliance with Laws.** Seller shall be responsible for complying with all applicable federal, state and local laws, regulations and standards. Seller is responsible for any costs of such compliance. Seller certifies that it and all of its subcontractors to be used in the performance of this Purchase Agreement are in compliance with 25 O.S. Sec. 1313 and participate in the Status Verification System. The Status Verification System is defined in 25 O.S. Sec. 1312 and includes but is not limited to the free Employee Verification Program (E-Verify) available at www.dhs.gov/E-Verify.
14. **Termination.** City, by written notice, may terminate this Agreement, in whole or in part, when such action is in the best interest of City. If this Agreement is so terminated, City shall be liable only for payment for Goods accepted and Services rendered prior to the effective date of termination. City's right to terminate this Agreement is cumulative to any other rights and remedies provided by law or by this Agreement.
15. **Price Changes.** The parties understand and agree that the variables in Seller's cost of performance may fluctuate, but any change in Seller's cost of performance will not alter its obligations under this Agreement, nor excuse performance or delay on Seller's part. If the IFB provides that Seller may include a price escalation provision in its Bid, Seller's price escalation provision will be evaluated by City as part of Seller's Bid price when awarding the Bid.
16. **Right to Audit.** The parties agree that Seller's books, records, documents, accounting procedures, practices, price lists or any other items related to the Goods and/or Services provided hereunder are subject to inspection, examination, and copying by City or its designees. Seller is required to retain all records related to this Agreement for the duration of the term of this Agreement and a period of three years following completion and/or termination of the Agreement. If an audit, litigation or other action involving such records begins before the end of the three year period, the records shall be maintained for three years after the date that all issues arising out of the action are resolved or until the end of the three year retention period, whichever is later.
17. **Notice.** Any notice, demand, or request required by or made pursuant to this Agreement shall be deemed properly made if personally delivered in writing or deposited in the United States mail, postage prepaid, to the addresses specified below.

i. To Seller: _____

To CITY: City Clerk
CITY OF TULSA, OKLAHOMA
175 E. 2nd Street, Suite 260
Tulsa, Oklahoma 74103

18. Relationship of Parties. The Seller is, and shall remain at all times, an independent contractor with respect to activities and conduct while engaged in the performance of services for the City under this Agreement. No employees, subcontractors or agents of the Seller shall be deemed to be employees of the City for any purpose whatsoever, and none shall be eligible to participate in any benefit program provided by the City for its employees. The Seller shall be solely responsible for the payment of all employee wages and salaries, taxes, withholding



**Invitation For Bid (IFB)
#TAC528D Backhoes
Issued: October 20, 2011
City of Tulsa**

**City of Tulsa,
Oklahoma**
Page 7 of 46

**FORM #2 (Page 3 of 4)
PURCHASE AGREEMENT**

payments, fringe benefits, insurance premiums, continuing education courses, materials or related expenses on behalf of its employees, subcontractors, and agents. Nothing in this Agreement shall be construed to create a partnership, joint venture, or agency relationship among the parties. No party shall have any right, power or authority to act as a legal representative of another party, and no party shall have any power to obligate or bind another party, or to make any representations, express or implied, on behalf of or in the name of the other in any manner or for any purpose whatsoever.

19. **Third Parties.** This Agreement is between City and Seller and creates no right unto or duties to any other person. No person is or shall be deemed a third party beneficiary of this Agreement.
20. **Time of Essence.** City and Seller agree that time is deemed to be of the essence with respect to this Agreement.
21. **Binding Effect.** This Agreement shall be binding upon City and Seller and their respective successors, heirs, legal representatives and permitted assigns.
22. **Headings.** The headings used herein are for convenience only and shall not be used in interpreting this Agreement
23. **Severability Provision.** If any term or provision herein is determined to be illegal or unenforceable, the remainder of this Agreement will not be affected thereby. It is the intention of the parties that if any provision is held to be illegal, invalid or unenforceable, there will be added in lieu thereof a provision as similar in terms to such provision as is possible to be legal, valid and enforceable.
24. **Governing Law And Venue.** This Agreement is executed in and shall be governed by and construed in accordance with the laws of the State of Oklahoma without regard to its choice of law principles, which shall be the forum for any lawsuits arising under this Agreement or incident thereto. The parties stipulate that venue is proper in a court of competent jurisdiction in Tulsa County, Oklahoma and each party waives any objection to such venue. City does not and will not agree to binding arbitration of any disputes.
25. **No Waiver.** A waiver of any breach of any provision of this Agreement shall not constitute or operate as a waiver of any other provision, nor shall any failure to enforce any provision hereof operate as a waiver of the enforcement of such provision or any other provision.
26. **Entire Agreement/No Assignment.** This Agreement and any documents incorporated herein constitute the entire agreement of the parties and supersede any and all prior agreements, oral or otherwise. This Agreement may only be modified or amended in a writing signed by both parties. Notwithstanding anything to the contrary stated herein or in the attachments to this Agreement, no future agreements, revisions or modifications that may be required under this Agreement are effective or enforceable unless such terms, revisions or modifications have been reduced to writing and signed by City and Seller. Seller may not assign this Agreement or use subcontractors to provide the Goods and/or Services without City's prior written consent. Seller shall not be entitled to any claim for extras of any kind or nature.
27. **Multiple Counterparts.** This Agreement may be executed in several counterparts, each of which shall be deemed an original, but which together shall constitute one and the same instrument.
28. **Interpretive Matters and Definitions.** The following interpretive matters shall be applicable to this Agreement:
 - 28.1 Unless the context otherwise requires: (a) all references to Sections are to Sections of or to this Agreement; (b) each term defined in this Agreement has the meaning assigned to it; (c) "or" is disjunctive but not necessarily exclusive; (d) words in a singular include the plural and vice versa. All references to "\$" or to dollar amounts shall be in lawful currency of the United States of America;
 - 28.2 No provision of this Agreement will be interpreted in favor of, or against, any of the parties hereto by reason of the extent to which such party or its counsel participated in the drafting thereof or by reason of the extent to which any such provision is inconsistent with any prior draft hereof or thereof;
 - 28.3 Any reference to any applicable laws shall be deemed to refer to all rules and regulations promulgated thereunder and judicial interpretations thereof, unless the context requires otherwise;
 - 28.4 The word "including" means "including, without limitation" and does not limit the preceding words or terms; and
 - 28.5 All words used in this Agreement shall be construed to be of such gender, number or tense as circumstances require.
29. **Minority, Female, and Disadvantaged Business Enterprises and Equal Employment Opportunity.** Each bidder agrees to comply with the terms of Title 5 of Tulsa Revised Ordinances relating to Equal Employment Opportunity and to the utilization of minority, female, disadvantaged and BRIDGE program companies.
30. **Authority to Bind.** The undersigned individual states that s/he has authority to bind Seller to this Agreement, that s/he has read and understands the terms of this Agreement, and that Seller agrees to be bound by this Agreement and its incorporated documents.

**FORM #2 (Page 4 of 4)
PURCHASE AGREEMENT**



Invitation For Bid (IFB)
#TAC528D Backhoes
Issued: October 20, 2011
City of Tulsa

City of Tulsa,
Oklahoma
 Page 9 of 46

FORM #3

INTEREST AFFIDAVIT

STATE OF _____)
)ss.
 COUNTY OF _____)

I, _____, of lawful age, being first duly sworn, state that I am the agent authorized by Seller to submit the attached Bid. Affiant further states that no officer or employee of the City of Tulsa either directly or indirectly owns a five percent (5%) interest or more in the Bidder's business or such a percentage that constitutes a controlling interest. Affiant further states that the following officers and/or employees of the City of Tulsa own an interest in the Bidder's business which is less than a controlling interest, either direct or indirect.

By: _____
 Signature

Title: _____

Subscribed and sworn to before me this _____ day of _____, 20____.

 Notary Public

My Commission Expires: _____

Notary Commission Number: _____

County & State Where Notarized: _____

The Affidavit must be signed by an authorized agent and notarized



Invitation For Bid (IFB)
#TAC528D Backhoes
Issued: October 20, 2011
City of Tulsa

City of Tulsa,
Oklahoma
 Page 11 of 46

FORM #5

AFFIDAVIT OF CLAIMANT

STATE OF _____)
)ss.
 COUNTY OF _____)

The undersigned person, of lawful age, being first duly sworn on oath, says that all invoices to be submitted pursuant to this agreement with the City of Tulsa will be true and correct. Affiant further states that the work, services or material furnished will be completed or supplied in accordance with the plans, specifications, orders, requests and/or contract furnished or executed by the affiant. Affiant further states that (s)he has made no payment directly or indirectly to any elected official, officer or employee of the City of Tulsa or of any public trust where the City of Tulsa is a beneficiary, of money or any other thing of value to obtain payment of the invoice or procure the contract or purchase order pursuant to which an invoice is submitted. Affiant further certifies that (s)he has complied with all applicable laws regarding equal employment opportunity.

Company: _____

Remit to
 Address: _____

City, State
 Zip: _____

Phone: _____

Name (print): _____

Signature: _____

Title: _____

Subscribed and sworn to before me this _____ day of _____, 20____.

 Notary Public

My commission expires: _____
 My commission number: _____
 County and State where notarized: _____

The Affidavit must be signed by an authorized agent and notarized



Invitation For Bid (IFB)
#TAC528D Backhoes
Issued: October 20, 2011
City of Tulsa

City of Tulsa,
Oklahoma
Page 12 of 46

FORM #6

ACKNOWLEDGMENT OF RECEIPT OF ADDENDA/AMENDMENTS

I hereby acknowledge receipt of the following addenda or amendments, and understand that such addenda or amendments are incorporated into the Bid Packet and will become a part of any resulting contract.

List Date and Title/Number of all addenda or amendments: (Write "None" if applicable).



Sign Here ► _____

Printed Name: _____

Title: _____

Date: _____

INSTRUCTIONS, TERMS AND CONDITIONS FOR BIDDERS

1. **PURCHASING AUTHORITY.** City issues this Invitation For Bid pursuant to Tulsa City Charter, Art. XII, §14 and Tulsa Revised Ordinances, Title 6, Ch. 4, the provisions of which are incorporated herein.
2. **DEFINITIONS.** The following terms have the following meanings when used in the documents comprising this Bid Packet.
 - A. **“Acceptance”** with respect to a Bid shall mean the City’s selection of a Bid, and award of a contract to the Bidder/Seller.
 - B. **“Acceptance”** with respect to delivery of Goods and/or Services provided under a Purchase Agreement shall mean City’s written acknowledgement that Seller has satisfactorily provided such Goods and/or Services as required.
 - C. **“Addenda” “Addendum” or “Amendment(s)”** shall mean a clarification, revision, addition, or deletion to this Invitation For Bid by City which shall become a part of the agreement between the parties.
 - D. **“Authorized Agent”** means an agent who is legally authorized to bind the Seller under the law of the State in which the Seller is legally organized. An Authorized Agent must sign all documents in the Bid Packet on behalf of the Seller. Under Oklahoma law, the Authorized Agent for each of the following types of entities is as stated below:
 - **Corporations** – the president, vice president, board chair or board vice chair can sign; others can sign if they have and provide the City with (i) a corporate resolution giving them authority to bind the Seller, and (ii) a recent corporate secretary’s certificate indicating the authority is still valid.
 - **General Partnerships** – any partner can sign to bind all partners.
 - **Limited Partnerships** – the general partner must sign.
 - **Individuals** – no additional authorization is required, but signatures must be witnessed and notarized.
 - **Sole Proprietorship** – the owner can sign. Any other person can sign if s/he provides a recent Power of Attorney, signed by the owner, authorizing him/her to bind the sole proprietorship.
 - **Limited Liability Company (LLC)** – The manager as named in the Operating Agreement can sign. Any person authorized by the Operating Agreement or a member can sign providing the person submits a copy of the authorization with a certificate of the members indicating the authorization is still valid.Entities organized in States other than Oklahoma must follow the law of the State in which they are organized.
 - E. **“Bid”** means the Seller’s offer to provide the requested Goods and/or Services set forth in Exhibit A and any additional materials or information the Seller chooses to submit to support the Bid.
 - F. **“Bidder”** means the legal entity which submits a Bid for consideration by City in accordance with the Invitation For Bid.
 - G. **“Bid Packet”** consists of the following documents (1) the Notice of Invitation for Bid, (2) the Summary Sheet, (3) Form #1, (4) Form #2, (5) Form #3, (6) Form #4, (7) Form #5, (8) Form #6, (9) the Instructions, Terms and Conditions for Bidders, (10) Special Requirements, (11) Technical Specifications, and (12) Exhibit A.
 - H. **“Bid Submission Date”** shall mean the last date by which the City will accept Bids for an Invitation For Bid.
 - I. **“City”** shall mean the City of Tulsa, Oklahoma.
 - J. **“Days”** shall mean calendar days unless specified otherwise.
 - K. **“Primary Seller”** shall mean the Seller whose Bid City selected as the principal supplier of the Goods and/or Services required under this Agreement.
 - L. **“Project Buyer”** shall mean the City’s employee assigned to serve as the contact person for Bidders/Sellers responding to Invitations For Bid or completing contracts herein.
 - M. **“Purchasing Division or Office”** shall mean the City of Tulsa’s Purchasing Division, located at 175 East 2nd Street, Suite 865, Tulsa, Oklahoma 74103
 - N. **“Secondary Seller”** shall mean the Seller whose Bid City selected as a back-up supplier in the event the Primary Seller is unable to provide all the Goods and/or Services required.



Invitation For Bid (IFB)
#TAC528D Backhoes
Issued: October 20, 2011
City of Tulsa

City of Tulsa,
Oklahoma
Page 14 of 46

- O. **“Seller”** shall mean the Bidder whose Bid City selected and awarded a contract.
- P. **“You” or “Your”** shall mean the Bidder responding to this Invitation For Bid or the Seller whose Bid the City selected and awarded a contract.
- Q. **“Website”** shall mean the City of Tulsa’s website for the Purchasing Division: www.cityoftulsapurchasing.org.

- 3. **QUESTIONS REGARDING INVITATION FOR BID.** Questions regarding any portion of this Invitation For Bid must be submitted in writing (sent by mail, fax or email) to the Project Buyer indicated on the Summary Sheet herein. You should submit questions as early as possible and preferably before the pre-Bid conference. Questions and concerns must be received no later than seven (7) days prior to the Bid Packet due date. Any oral responses to questions before the contract is awarded are not binding on City. At City’s discretion, any information or clarification made to you may be communicated to other Bidders that notified City of their intent to Bid if appropriate to ensure fairness in the process for all Bidders. You must not discuss questions regarding the Invitation For Bid with anyone other than the Project Buyer or other Purchasing Division staff or your Bid may be disqualified, any contract recommendation or Acceptance may be rescinded, or any contract may be terminated and delivered Goods returned at your expense and City refunded any payments made.
- 4. **ORAL STATEMENTS.** No oral statements by any person shall modify or otherwise affect the provisions of this Invitation For Bid and/or any contract resulting therefrom. All modifications, addenda or amendments must be made in writing by City’s Purchasing Division.
- 5. **EXAMINATION BY BIDDERS.** You must examine the specifications, drawings, schedules, special instructions and the documents in this Bid Packet prior to submitting any Bid. Failure to examine such documents and any errors made in the preparation of such Bid are at your own risk.
- 6. **ADDENDA OR AMENDMENTS TO INVITATIONS FOR BID.** City may addend or amend its Invitation For Bid at any time before the Bid Submission Date, and any such addenda or amendments shall become a part of this Agreement. City will attempt to send a notification (by fax or email) of any addenda or amendments to those Bidders who have responded to the City’s Project Buyer of their intent to respond to the Invitation For Bid. However, it is your responsibility to inquire about any addenda or amendments, which will be available from the City’s Purchasing Division and its website. You must acknowledge receipt of any addenda or amendments by signing and returning the Acknowledgment of Receipt of Addenda/Amendments form and attaching it to this Invitation For Bid with your Bid. City may reject any Bid that fails to acknowledge any addenda or amendments.
- 7. **SPECIFICATIONS/DESCRIPTIVE TERMS/SUBSTITUTIONS.** Unless the term “no substitute” is used, the City’s references to a brand name, manufacturer, make, or catalogue designation in describing an item in this Bid Packet does not restrict you to that brand or model, etc. The City may make such references to indicate the type, character, quality and/or performance equivalent of the item desired. However, you are required to furnish the exact item described in your Bid unless a proposed substitution is clearly noted and described in the Bid.

The parties recognize that technology may change during the period Bids are solicited and subsequent contracts are performed. Therefore, City may at its option accept changes or substitutions to the specifications for Goods of equal or better capabilities at no additional cost to City. In the case of existing contracts, you shall give City 30 days advance notice in writing of any such proposed changes or substitutions. City shall determine whether such items are acceptable as well as any proposed substitute.

All Goods shall be new unless otherwise so stated in the Bid. Any unsolicited alternate Bid, or any changes, insertions, or omissions to the terms and conditions, specifications, or any other requirements of this Bid, may be considered non-responsive and the Bid rejected.

- 8. **PRICES/DISCOUNTS.** Prices shall be stated in the units and quantity specified in the Bid Packet documents. In case of discrepancy in computing the Bid amount, you guarantee unit prices to be correct and such unit prices will govern. Prices shall include transportation, delivery, packing and container charges, prepaid by you to the destination specified in the Specifications. Discounts for prompt payment will not be considered in Bid evaluations, unless otherwise specified. However, offered discounts for prompt payment will be taken if payment is made within the discount period.
- 9. **DELIVERY.** All prices quoted shall be based on delivery F.O.B. Tulsa, Oklahoma or to any other points as may be designated in the Technical Specifications, with all charges prepaid by Seller to the actual point of delivery. Bids must state the number of days required for delivery under normal conditions.
- 10. **TAXES.** City is exempt from federal excise and state sales taxes and such taxes shall not be included in the Bid prices.



**Invitation For Bid (IFB)
#TAC528D Backhoes
Issued: October 20, 2011
City of Tulsa**

**City of Tulsa,
Oklahoma**
Page 15 of 46

11. **BID SUBMISSION.** The Bid Packet forms must be prepared in the name of Bidder and properly executed by an Authorized Agent with full knowledge and acceptance of all provisions, in ink and notarized. Bids may not be changed or withdrawn after the deadline for submitting Bids (the "Bid Submission Date"). A Bid is an irrevocable offer and when accepted by City (as evidenced by City's execution of the Purchase Agreement) shall constitute a firm contract.
- A. **BIDS MUST BE SUBMITTED ONLY ON THE BID PACKET FORMS AND SIGNED BY AN AUTHORIZED AGENT. THE ENTIRE BID PACKET MUST BE RETURNED AS RECEIVED WITH ALL FORMS COMPLETED. YOU MAY ATTACH, AFTER EXHIBIT A, ANY DOCUMENTS NECESSARY TO COMPLETELY AND ACCURATELY RESPOND TO THE REQUEST. BIDS MUST BE IN STRICT CONFORMANCE WITH ALL INSTRUCTIONS, FORMS, AND SPECIFICATIONS CONTAINED IN THIS BID PACKET.**
 - B. Sealed Bids may be either mailed or delivered, but must be received at:
City of Tulsa – Office of City Clerk
175 East 2nd Street, Suite 260
Tulsa, Oklahoma 74103
 - C. Bids will be accepted at the above address from 8:00 a.m. to 5:00 p.m., Monday thru Friday except for City holidays. City is not responsible for the failure of Bids to be received by the City Clerk's Office prior to the due date and time.
 - D. Late Bids will be **rejected**. The Purchasing Agent, in his sole discretion, may make exceptions only for the following reasons:
 - 1. City Hall closed for business for part or all of the day on the date the response was due;
 - 2. If the City deems it appropriate due to large-scale disruptions in the transportation industry that may have prevented delivery as required.
 - 3. If documented weather conditions caused the late delivery. You must provide documentation of such weather to the satisfaction of the Purchasing Agent.
 - E. **City will not accept faxed Bids**, nor will City accept Bids faxed to the City Clerk, Purchasing Division or Office, or any other City office or employee.
 - F. City is not responsible for any of your costs in preparing the Bid response, attending a pre-Bid conference, or any other costs you incur, regardless of whether the Bid is submitted, accepted or rejected.
 - G. All Bids must be securely sealed and plainly marked with the Bid Number, Bid Title, and Bid Opening Date on the lower left corner of the outside of the Bid envelope. Your name and address must also be clearly indicated on the envelope.
 - H. If submitting multiple options ("Option(s)") to the Invitation for Bid, each will be considered separately requiring each response to be complete and accurate. Each Option must be clearly marked as Option 1 of 3, Option 2 of 3, etc.
 - I. The number of copies you must submit is listed on the Summary Sheet in the front of the Bid Packet. However, at a minimum, there will be (1) an original, clearly labeled as such in 1" red letters on the Bid Packet cover page, and (2) a copy for City's Purchasing Division, clearly labeled as such in 1" red letters on the Bid Packet cover page. If binders are used, they must also be labeled.
 - J. Multiple boxes or envelopes are permissible, but must not weigh more than 50 pounds. Each box must be labeled as instructed herein and numbered (i.e., Box 1 of 3; Box 2 of 3). **The original must be in Box #1.**
 - K. The original and all copies (either paper or electronic) must be identical in all respects. Bids must be completed and submitted in ink or typewritten. Bids written in pencil will be rejected. Any corrections to the Bids must be initialed in ink.
12. **BID REJECTION OR WITHDRAWL.**
- A. City may reject any or all Bids, in whole or in part.
 - B. **A Bid may be rejected if it contains additional terms, conditions, or agreements that modify the requirements of this Invitation For Bid or attempts to limit Bidder's liability to the City.**
 - C. A Bid may be rejected if Bidder is currently in default to City on any other contract or has an outstanding indebtedness of any kind to City.
 - D. City reserves the right to waive any formalities or minor irregularities, defects, or errors in Bids.
 - E. Bid withdrawal may only be accomplished by an Authorized Agent requesting the withdrawal in person at the City Clerk's office before the City's close of business on the Bid Submission Date.
13. **BID RESULTS.** A tabulation of Bids received will be made available on the City's Purchasing Division website generally within 5 working days after the Bid Opening Date. After a contract award is recommended to the Mayor, a copy of the Bid summary will be available in the City Clerk's Office. Bid results are not provided in response to telephone or email inquiries.
14. **PURCHASE ORDER.** In the event that the successful Bid is for an amount less than One Hundred Thousand Dollars (\$100,000), and it is determined by the City to be in the best interests of the City, the City, in its sole discretion, may issue a Purchase Order rather than execute the Purchase Agreement to purchase the Goods. If a Purchase Order is issued, however, the terms of the Bid Packet documents, including the Purchase Agreement, will govern the transaction and be enforceable by the City and Bidder/Seller.
15. **CONTRACT AWARD.** If a contract is awarded, it will be awarded to the Bidder that City determines is the lowest secure Bidder meeting specifications. Such Bid analysis will consider price and other factors, such as Bidder qualifications and financial ability to



Invitation For Bid (IFB)
#TAC528D Backhoes
Issued: October 20, 2011
City of Tulsa

City of Tulsa,
Oklahoma
Page 16 of 46

perform the contract, as well as operating costs, delivery time, maintenance requirements, performance data, history of contract relations with City, and guarantees of materials and equipment, as applicable. A complete list of the factors that are considered is set forth in Tulsa Revised Ordinances, Title 6, Ch. 4, §406E. Unless otherwise noted, City reserves the right to award a contract by item, one or more groups of items, or all the items in the Bid, whichever is in City's best interest.

16. **IRS FORM W-9.** If City selects your Bid and awards a contract to you, you will have ten (10) days from notification of the award to provide City with your complete IRS Form W-9.
17. **NOTICE TO PROCEED.** If City accepts your Bid and executes the Purchase Agreement, you shall not commence work until authorized to do so by the Purchasing Agent or his representative. Receipt of a Purchase Order from the City is notice to proceed.
18. **PAYMENTS.** Invoices should be mailed to: City of Tulsa – Accounts Payable
175 East 2nd Street, 8th floor
Tulsa, Oklahoma 74103

Payment will be made Net 30 days after receipt of a properly submitted invoice or the City's Acceptance of the Goods and/or Services, whichever is later, unless City decides to take advantage of any prompt payment discount included in the Bid.

THE REST OF THIS PAGE LEFT INTENTIONALLY BLANK





**Invitation For Bid (IFB)
#TAC528D Backhoes
Issued: October 20, 2011
City of Tulsa**

**City of Tulsa,
Oklahoma**
Page 17 of 46

SPECIAL REQUIREMENTS

1. Irrevocable Offer Period. You understand and acknowledge that the offer submitted as your Bid is firm and irrevocable from the City's close of business on the Bid Submission Date until 120 days after the Bid Opening Date.

2. General Liability/Indemnification. You shall hold City harmless for any loss, damage or claims arising from or related to your performance of the Purchase Agreement. You must exercise all reasonable and customary precautions to prevent any harm or loss to all persons and property related to the Purchase Agreement. You agree to indemnify and hold the City harmless from all claims, demands, causes of action or suits of whatever nature arising out of the Goods, Services, labor, or materials furnished by you or your subcontractors under the provisions of the Bid Packet documents.

3. Liens. Pursuant to City's Charter (Art. XII, §5), no lien of any kind shall exist against any property of City. Bidder shall deliver all goods to City free and clear of liens. Delivery by Seller to City of goods which are subject to liens under the Purchase Agreement shall be a material breach of the Purchase Agreement and all damages and costs incurred by City as a result of the existence of such liens shall be paid to City by Seller. At City's option, City may return such goods to Seller and Seller shall pay the cost of returning such goods and reimburse City for any payments made for such goods.

4. Insurance. If checked "Yes," the following insurance is **required:** **No: X**

Seller and its subcontractors must obtain at Seller's expense and keep in effect during the term of the Purchase Agreement, including any renewal periods, policies of General Liability insurance in the minimum amounts set forth below and Workers' Compensation insurance in the statutory limits required by law.

Personal injury, each person	\$ 175,000.00
Property damage, each person	\$ 25,000.00
Auto Liability, each occurrence	\$ 1,000,000.00
Personal injury and property damage, each occurrence	\$ 1,000,000.00
Workers' Compensation	(Statutory limits)

SELLER'S INSURER MUST BE AUTHORIZED TO TRANSACT BUSINESS IN THE STATE OF OKLAHOMA.

Seller's insurance policy and all certificates of insurance must state that the insurer cannot change or cancel coverage without the insurer first giving 30 days written notice to City of such change, cancellation or termination. You will have 10 days after notification that your Bid was selected for contract award by City to provide proof of such coverage. The Certificate of Insurance must be completed with the following information:

- A. Your name
- B. Insurer's name and address;
- C. Policy number;
- D. Liability coverage and amounts;
- E. Commencement and expiration dates;
- F. Signature of authorized agent of insurer;
- G. Invitation For Bid number.

The completed Certificate of Insurance form should be sent to the assigned Project Buyer reflected on the Summary Sheet of this Bid Packet. An endorsement from the insurer must be obtained by Seller which adds City as an Additional Insured to the policy and states that the insurer will provide City with notice thirty days in advance of termination, cancellation or change in the coverage of the policy. The cancellation clause on your certificate must conform to the endorsement. Any conflict between the endorsement and the certificate is a material breach of the Purchase Agreement and can result in the retraction by City of the award of the Bid to Seller

5. Bonding.

A. Bid Bond. If the box is checked "Yes," the Bid Bond is **required:**

No: X



**Invitation For Bid (IFB)
#TAC528D Backhoes
Issued: October 20, 2011
City of Tulsa**

**City of Tulsa,
Oklahoma**
Page 18 of 46

B. Performance Bond. If the box is checked "Yes," the Performance Bond is **required**:

No: X

6. References. If the box is checked "Yes," References are **required**:

No: X (Only upon request)

For each reference, the following information must be included: Company Name, Contact Name, Address, Phone Number, E-Mail Address, and the nature of their relationship with the Bidder.

THE REST OF THIS PAGE LEFT INTENTIONALLY BLANK



**Invitation For Bid (IFB)
#TAC528D Backhoes
Issued: October 20, 2011
City of Tulsa**

**City of Tulsa,
Oklahoma**
Page 19 of 46

TECHNICAL SPECIFICATIONS

ITEM 1: 2 WHEEL DRIVE BACKHOE SPECIFICATION

ATTENTION: IN SECTION 2 (BIDDER'S PROPOSAL COLUMN). THE BIDDER SHALL RESPOND TO EACH MINIMUM REQUIREMENT (SECTION 1) IN THE SPACE PROVIDED UNDER SECTION 2 WHENEVER ASKED TO "DESCRIBE". THE DESCRIPTION MAY INCLUDE DETAILS SUCH AS SIZES, CAPACITIES, DIMENSIONS, MATERIALS USED IN CONSTRUCTION, ETC. A FULL AND COMPLETE DESCRIPTION IS REQUIRED TO REASONABLY EVALUATE THE BID, SO ALL PERTINENT INFORMATION IS REQUIRED. WHEN REFERRING TO ATTACHED LITERATURE AS A MEANS OF NOT FULLY DESCRIBING ITEMS, MISINTERPRETATIONS BY THE EVALUATOR OF THE BID MAY OCCUR AND CONSEQUENTLY NOT HAVING THE BID AWARDED. YOUR ABILITY TO PRESENT THE CITY WITH ENOUGH INFORMATION TO REASONABLY UNDERSTAND THE ITEM BEING BID AND WHETHER OR NOT IT MEETS THE SPECIFICATIONS STATED RELIES ON THE WRITTEN INFORMATION PROVIDED.

YOU ARE REQUESTED TO DESCRIBE YOUR PROPOSAL IN THE BIDDERS COLUMN, **YOU MAY NOT RESPOND** IN THE SPACE PROVIDED AS TO WHETHER YOU MEET SPECIFICATIONS BY RESPONDING WITH TERMS SUCH AS "YES", "MEETS" "SAME AS", "COMPLIES", OR SIMILAR TERMS. IF THESE TERMS ARE UTILIZED, IT WILL LIKELY RESULT IN YOUR BID BEING CONSIDERED AS NON-COMPLIANT, AND BEING REJECTED.

YOU MUST INCLUDE DESCRIPTIVE LITERATURE. FAILURE TO PROVIDE SUCH LITERATURE WILL LIKELY RESULT IN YOUR BID BEING CONSIDERED AS NON-COMPLIANT, AND BEING REJECTED.

IF YOUR RESPONSE IS AN ALTERNATE APPROACH AND DOES NOT FULLY MEET THE SPECIFICATIONS, COMPLETELY DESCRIBE YOUR ALTERNATE APPROACH.

ALL ITEMS, INCLUDING VEHICLES & EQUIPMENT BID ARE SUBJECT TO A PERFORMANCE DEMONSTRATION WITHIN 30 DAYS OF THE BID DATE BY THE VENDOR(S) AT THE DESCRETION OF THE CITY OF TULSA. A LIKE ITEM OF THE TYPE BID, THAT CONTAINS ALL THE SAFETY CONCERNS, HORSEPOWER RATINGS, ACCESSORIES, DIMENSIONS, OR OTHER FEATURES AS DEEMED APPROPRIATE BY THE CITY OF TULSA MAY BE REQUIRED TO BE DEMONSTRATED TO CITY OF TULSA PERSONNEL PRIOR TO AWARD OF BID TO ESTABLISH IF THE ITEM MEETS THE REQUIREMENTS & SPECIFICATIONS OF THE CITY OF TULSA. THESE DEMONSTRATIONS MAY BE HELD IN DIRECT COMPETITION WITH OTHER VENDORS WHOM BID THE SAME ITEMS AND EQUIPMENT.

ALL MATERIAL/EQUIPMENT BID SHALL BE NEW AND THE LATEST PRODUCTION MODEL. BROCHURES AND/OR SPECIFICATION LITERATURE CLEARLY DESCRIBING THE UNITS AND VERIFYING THAT THE UNITS MEET OR EXCEED THE REQUIREMENTS OF THIS SPECIFICATION SHALL ACCOMPANY EACH BID PROPOSAL. WARRANTY AND DELIVERY INFORMATION SHALL ALSO BE PROVIDED WITH THE BID PROPOSAL. ANY MANUFACTURE'S NAME AND MODEL CALLED OUT IN THIS BID IS INTENDED TO SET THE QUALITY AND DESIGN OF EQUIPMENT DESIRED AND IS NOT MEANT TO LIMIT BIDDING ON PRODUCTS OF EQUAL QUALITY. ANY EXCEPTIONS TO OR DEVIATIONS FROM THE SPECIFICATIONS SET FORTH IN THE BID MUST BE CLEARLY DESCRIBED IN THE BIDDER'S PROPOSAL.

DURING A STANDARD WARRANTY PERIOD OR FOR ANY EXTENDED WARRANTY AND PREVENTIVE MAINTENANCE PERIOD SPECIFIED, NO UPCHARGES, OVERTIME, MILEAGE, OR FREIGHT, OR OTHER CHARGES FOR PARTS AND SERVICE SHALL BE CHARGED TO CITY OF TULSA PERTAINING TO WARRANTY REPAIRS OR PREVENTIVE MAINTENANCE.

SECTION 1

SECTION 2

ITEM SPECIFICATIONS (MINIMUM)

EQUIPMENT DESCRIPTION CURRENT YEAR MODEL TWO (2) WHEEL DRIVE BACKHOE / FRONT END LOADER **WITH AN OPTION TO PURCHASE A 4WHEEL DRIVE BACKHOE.**

BIDDER'S PROPOSAL

DESCRIBE:
YEAR: _____
MANUFACTURER: _____
MODEL NUMBER: _____

ENGINE – MUST CONFORM TO CURRENT EPA INTERIM TIER IV

1. FUEL: DIESEL
2. SAE NET H.P.: 90 TURBOCHARGED
3. NUMBER OF CYLINDERS: 4
4. AIR CLEANER(S): DRY-TYPE, DUAL

DESCRIBE:



**Invitation For Bid (IFB)
#TAC528D Backhoes
Issued: October 20, 2011
City of Tulsa**

**City of Tulsa,
Oklahoma**
Page 26 of 46

COLOR	1. MANUFACTURER'S STANDARD.	<u>DESCRIBE:</u> _____
ADDITIONAL EQUIPMENT	1. BACKUP ALARM: INCLUDE 2. HORN: INCLUDE 3. SMV EMBLEM: INCLUDE 4. DISH FENDERS: INCLUDE 5. FULL LOCKUP PACKAGE: INCLUDE (LOCKABLE DOORS) 6. TOOL BOX: INCLUDE (LOCKABLE) 7. STREET PADS: INCLUDE 130 LB. RUBBERIZED / REVERSIBLE.	<u>DESCRIBE:</u> _____ _____ _____ _____ _____ _____ _____ _____ _____ _____
WEIGHTS	1. WEIGHTS: MANUFACTURER'S RECOMMENDATION FOR BALANCE.	<u>DESCRIBE:</u> _____ _____
OPERATING WEIGHT	1. APPROXIMATELY 16,000 LBS.	<u>DESCRIBE:</u> _____
TRAINING	THE SUCCESSFUL BIDDER SHALL SUPPLY AT NO ADDITIONAL COST TO THE CITY, A MINIMUM OF EIGHT (8) HOURS TRAINING ON OPERATION AND ROUTINE SERVICE. TRAINING SHALL BE AT THE CITY OF TULSA FACILITIES WITHIN ONE (1) WEEK OF DELIVERY OF THE MACHINE.	<u>DESCRIBE:</u> _____ _____ _____ _____ _____ _____ _____
PARTS AND SERVICE	DUE TO THE EMERGENCY WORK ENVIRONMENT OF THIS MACHINE, THE BIDDER SHALL HAVE A FACILITY WITHIN 1 HOURS DRIVE FROM THE CITY OF TULSA FOR PARTS AND SERVICE AVAILABILITY.	<u>DESCRIBE:</u> _____ _____ _____ _____ _____ _____
MANUFACTURER'S STANDARD WARRANTY	ONE YEAR/1,000 HOUR MANUFACTURERS STD.	<u>DESCRIBE:</u> _____ _____ _____ _____
EXTENDED WARRANTY	IN ADDITION TO THE STANDARD MANUFACTURER'S 12 MONTH WARRANTY; THE SUCCESSFUL BIDDER SHALL SUPPLY AN EXTENDED WARRANTY FOR AN ADDITIONAL 4 YEARS/ 4,000 HOURS, FOR A TOTAL OF 5 YEARS, 5,000 HOURS. THE WARRANTY SHALL BE COMPLETE MACHINE COVERAGE INCLUDING THE ENGINE, TRANSMISSION, AND POWERTRAIN.	<u>DESCRIBE:</u> _____ _____ _____ _____ _____ _____ _____ _____



Invitation For Bid (IFB)
#TAC528D Backhoes
Issued: October 20, 2011
City of Tulsa

City of Tulsa,
Oklahoma
Page 28 of 46

(F) PERFORM SAME SERVICE AS PERFORMED AT 200 HOURS.

EVERY 1000 HOURS

- (A) CHANGE SPLITTER GEARBOX OIL.
- (B) CHANGE INNER AND OUTER FINAL DRIVE OIL.
- (C) CLEAN ENGINE CRANKCASE VENT TUBE.
- (D) MEASURE AND ADJUST ENGINE VALVE CLEARANCES.
- (E) PERFORM SAME SERVICES AS PERFORMED AT 200 AND 500 HOURS.

EVERY 3000/5000 HOURS

- (A) CHANGE HYDRAULIC OIL AND FILTER.
- (B) CHANGE TRANSMISSION OIL AND FILTER.
- (C) PERFORM SAME SERVICES AS PERFORMED AT 200, 500, AND 1000 HOURS

LOAD HOLDING SAFETY VALVE SPECIFICATIONS NEXT PAGE

Balance of page intentionally left blank

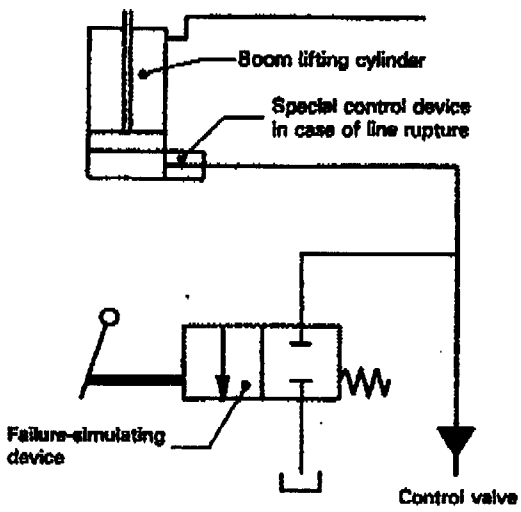

Figure 1

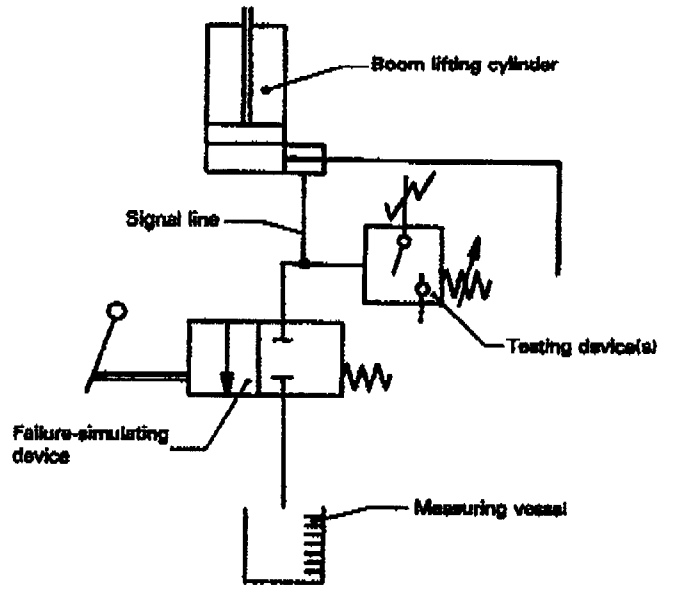

Figure 2

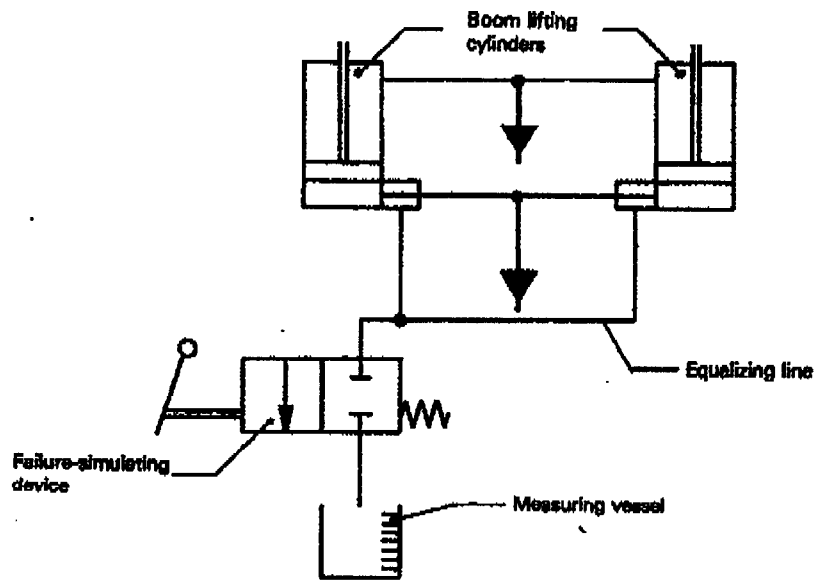

Figure 3

INTERNATIONAL STANDARD – ISO 8643 First Edition 1998-02,01

ISO (The **International Organization for Standardization**) is a worldwide federation of national standards bodies (ISO member bodies). The work of preparing International Standards is normally carried out through ISO technical committees. Each member body interested in a subject for which a technical committee has been established has the right to be represented on that committee. International organizations, governmental and non-governmental, in liaison with ISO, also take part in the work.

Draft International Standards, adopted by the technical committees, are circulated to the member bodies for approval before their acceptance as International Standards by ISO Council. They are approved in accordance with ISO procedures requiring at least 75% approval by the member bodies voting.

International Standard ISO 8643 was prepared by Technical Committee ISO/TC 127, **Earth Moving Machinery**.

Users should note that all International Standards undergo revision from time to time and that any reference made herein to any other International Standard Implies its latest edition, unless otherwise stated.

EARTH-MOVING MACHINERY—HYDRAULIC EXCAVATOR AND BACKHOE LOADER BOOM LOWERING CONTROL DEVICE REQUIREMENTS AND TESTS.

0 Introduction

Where national regulations permit use of excavators or backhoe loaders for lifting operations, a failure in the hydraulic boom circuit may endanger persons under raised loads.

This risk can be reduced by applying a control device, which ensures controlled load lowering in case of failure or rupture in the boom circuit.

Test procedures are based on the special design characteristics of the hydraulic systems of hydraulic excavators and the backhoe part of backhoe loaders, and conditions of use.

1 Scope

This International Standard establishes uniform requirements and test procedures for boom lowering control devices fitted on boom lift cylinders to control the rate of drop in case of a hydraulic line failure or rupture.

2 Field of Application

This International Standard applies to boom control lowering devices on hydraulic excavators and the backhoe part of backhoe loaders, when used for lifting of loads.

3 References

ISO 6165, Earth-Moving machinery – Basic Types – Vocabulary.

4 Definitions

4.1 Boom Control System. Hydraulic control valve (s) (including pilot and slave valves) used for raising and lowering of the boom.

4.2 Rated Lift Capacity. Smaller of either the rated tipping capacity or the rated hydraulic lift capacity.

4.3 Lift point. One point as defined by the manufacturer for purpose of lifting. It is defined by lift point height and lift point radius.

4.4 Lift Point Height. Vertical distance from the lift point to the ground reference plane (GRP).

4.5 Lift Point Radius. Horizontal distance from the lift point to the axis of rotation.

5 Requirements for Lifting Loads

5.1 For hydraulic excavators and the backhoe part of backhoe loaders used in lifting operations, a controlled lowering device shall be provided which prevents uncontrolled lowering of the boom in case of a hydraulic line failure or rupture.

5.2 Such control devices shall operate automatically while raising, holding and lowering loads. In case of line rupture during down movement, the increase in the initial lowering speed shall be less than 200 mm/s, measured at the load, whatever the height of the fall. After the operator returns the control to neutral position, the drop rate of the load shall not exceed 10 mm/s, allowable for internal leakage in the system.

5.3 The operation of the boom control lowering device shall not detract from the normal response of the machine and shall not, at any time, endanger the stability of the machine.

5.4 A relief valve to protect the cylinder may be fitted between the cylinder and the control device.

5.5 In case of a failure of the boom control system, or after a boom line rupture, lowering of the load shall be possible without endangering person(s) or the stability of the machine.

5.6 except for tubes and fittings integrated into the cylinder assembly and supported at both ends, tubes and hoses shall not be used to connect:

(a) the lift cylinder to the control device;

(b) the lift cylinder to the relief valve when it is in parallel with the control device.

Tubes and fittings integrated into the cylinder assembly shall have a minimum burst pressure of four times the relief valve pressure for that part of the system.

5.7 Signal lines for testing device(s) and equalizing lines between lift cylinders are permissible, if rupture of one of those lines results in oil leakage of not more than 10 /min for each cylinder at approximately 40 to 60 degrees C oil temperature at the specified operating

pressure.

6 Test Method

6.1 Apparatus

6.1.1 Stop Watch

6.1.2 Measuring Tape or Scale

6.1.3 Thermometer, measuring from 0 to 100 degrees C.

6.1.4. Measuring container, of 2 1 capacity of flowmeter.

6.1.5 Collecting container, for hydraulic oil or alternatively oil return line to tank.

6.1.6 Test load, a mass (50 +/- 10) % of the rated lift capacity at a specific lift point radius.

NOTE – Test methods ensuring equal results may be used, for example, a level size near a vertical wall to which a paper is pinned to record the load displacement in the tube or hose rupture simulation test, where the load is fitted with a stylus.

6.2 Preparation for Test

6.2.1 A failure-simulating device shall be installed in any connecting line the failure of which could cause the boom to lower. The tube for testing shall not increase the resistance of the connecting line.

Examples of such installations are:

(a) in the line between boom lift cylinder and control valve as shown in figure 1,

(b) in the signal line between boom lift cylinder and testing device as shown in figure 2,

(c) in the equalizing line between boom lift cylinders as shown in figure 3.

6.2.2 The complete hydraulic system shall be operated until the hydraulic oil temperature in the oil reservoir is approximately 40 to 50 degrees C. The hydraulic fluid shall be the type and grade specified by the manufacturer.

6.3 Testing of Control device

6.3.1 The test load shall be at the lift point radius which results in a moment equal to (50 +/- 10) % of the moment developed by the rated lift capacity at a specific lift point radius.

6.3.2 The functions of boom raise and lower shall be smooth and at a reduced speed of max. 200 mm/s, measured at the test load.

6.3.3 The load shall be lowered and set down after each test in accordance with 5.5.

6.4 Test of Holding position

6.4.1 The test load shall be raised approximately 1 m above ground level, with the control valve(s) in neutral position.

6.4.2 The failure-simulating valve between lift cylinders and control valve shall be opened.

6.4.3 The total drop of the load during the initial 10 shall be measured. It shall not exceed 100 mm.

6.5 Testing During Raise Function

6.5.1 The test load shall be lifted smoothly and continuously without shock (see 6.3.2).

6.5.2 The failure-simulating valve between the lift cylinder(s) and the control valve shall be opened.

6.5.3 The total drop of the load during the initial 10 shall be measured. It shall not exceed 100 mm.

6.6 Test During Lowering Function

6.6.1 The test load shall be lowered smoothly and continuously without shock (see 6.3.2).

6.6.2 The failure-simulating device between the lift cylinder(s) and the control valve shall be opened.

6.6.3 The increase in the lowering speed of the test load shall be less than 100% increase of the initial speed. After the control is moved to the neutral position, the device shall be able to limit boom movement so that the total drop of the load during the initial 10 of the test does not exceed 100 mm.

6.7 Testing of Equalizing Lines or Signal Lines

6.7.1 Testing shall be performed without load.

6.7.2 The boom shall be raised to its maximum lift height, and the control valve kept in the "lift" position.

6.7.3 The failure-simulating device shall be opened.

6.7.4 The oil leakage per cylinder shall not exceed 10 1/min.

Ref: Backhoe/Loader 2WD & 4WD 11-12

Balance of page intentionally left blank

OIL SAMPLES

OIL SAMPLES SHALL BE TAKEN AND ANALYZED FROM EACH SYSTEM PRIOR TO THE RECOMMENDED DRAIN/CHANGE INTERVAL: 200, 500, 1000, 3000, 5000 HOURS. MAINTENANCE RECOMMENDATIONS SHALL BE SUPPLIED BASED ON THE OIL ANALYSIS AND OPERATING INFORMATION AS SUPPLIED.

FIRST 100 HOURS

(A) CHANGE ALL BREAK-IN OILS AND FLUIDS AND FILTERS AND TAKE OIL SAMPLES FOR TESTING.

EVERY 250 HOURS

- (A) CHANGE AIR, FUEL AND OIL FILTER ELEMENTS.
- (B) CHECK INNER AND OUTER FINAL DRIVE HOUSINGS OIL LEVEL.

EVERY 500 HOURS

- (A) LUBRICATE TRANSMISSION DRIVESHAFT UNIVERSAL UNITS (IF APPLICABLE ON MODEL FURNISHED).
- (B) ADD COOLANT CONDITIONER
- (C) CHECK AIR INTAKE HOSES.
- (D) CHANGE FUEL FILTER ELEMENT(S).
- (E) CHECK BATTERY ELECTROLYTE LEVEL AND TERMINALS.
- (F) PERFORM SAME SERVICE AS PERFORMED AT 200 HOURS.

EVERY 1000 HOURS

- (A) CHANGE SPLITTER GEARBOX OIL.
- (B) CHANGE INNER AND OUTER FINAL DRIVE OIL.
- (C) CLEAN ENGINE CRANKCASE VENT TUBE.
- (D) MEASURE AND ADJUST ENGINE VALVE CLEARANCES.
- (E) PERFORM SAME SERVICES AS PERFORMED AT 200 AND 500 HOURS.

EVERY 3000/5000 HOURS

- (A) CHANGE HYDRAULIC OIL AND FILTER.
- (B) CHANGE TRANSMISSION OIL AND FILTER.
- (C) PERFORM SAME SERVICES AS PERFORMED AT 200, 500, AND 1000 HOURS

LOAD HOLDING SAFETY VALVE SPECIFICATIONS: SEE NEXT PAGE

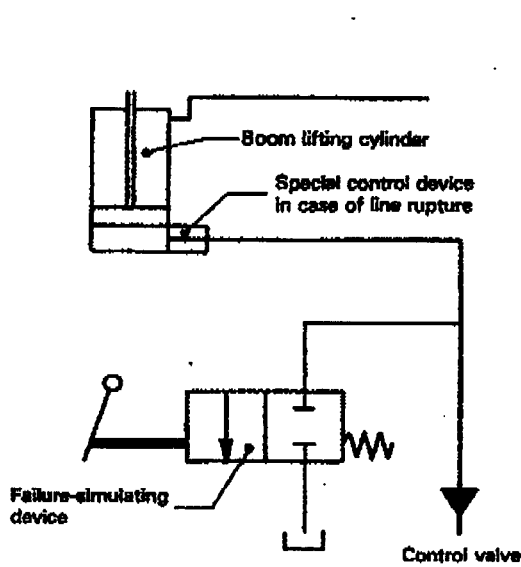

Figure 1

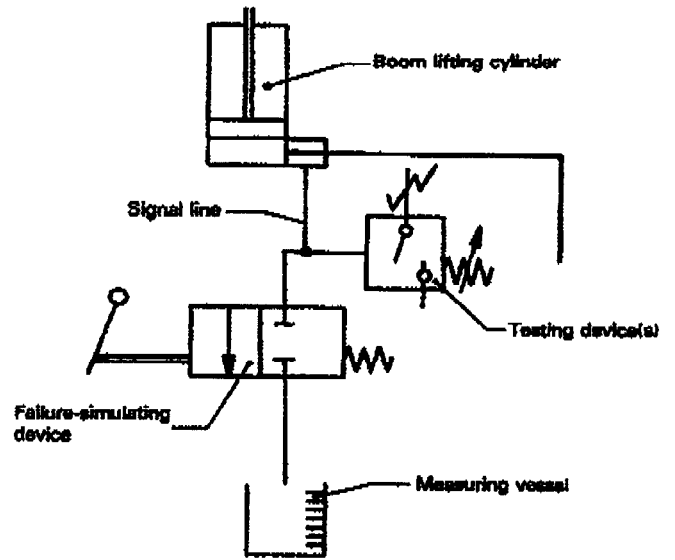

Figure 2

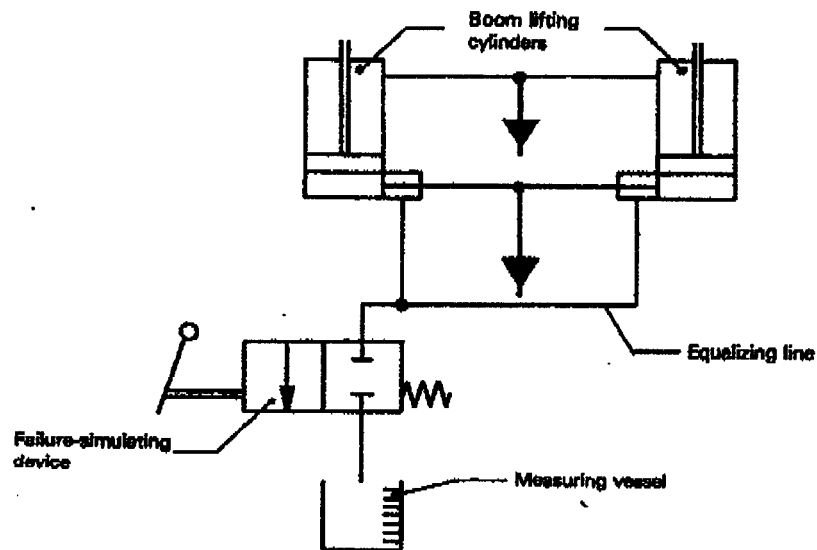

Figure 3

CITY OF TULSA STANDARD #000081

LOAD HOLDING VALVES FOR BACKHOES AND EXCAVATORS

INTERNATIONAL STANDARD – ISO 8643 First Edition 1998-02,01

ISO (The *International Organization for Standardization*) is a worldwide federation of national standards bodies (ISO member bodies). The work of preparing International Standards is normally carried out through ISO technical committees. Each member body interested in a subject for which a technical committee has been established has the right to be represented on that committee. International organizations, governmental and non-governmental, in liaison with ISO, also take part in the work.

Draft International Standards, adopted by the technical committees, are circulated to the member bodies for approval before their acceptance as International Standards by ISO Council. They are approved in accordance with ISO procedures requiring at least 75% approval by the member bodies voting.

International Standard ISO 8643 was prepared by Technical Committee ISO/TC 127, *Earth Moving Machinery*.

Users should note that all International Standards undergo revision from time to time and that any reference made herein to any other International Standard implies its latest edition, unless otherwise stated.

EARTH-MOVING MACHINERY—HYDRAULIC EXCAVATOR AND BACKHOE LOADER BOOM LOWERING CONTROL DEVICE REQUIREMENTS AND TESTS.

0 Introduction

Where national regulations permit use of excavators or backhoe loaders for lifting operations, a failure in the hydraulic boom circuit may endanger persons under raised loads.

This risk can be reduced by applying a control device, which ensures controlled load lowering in case of failure or rupture in the boom circuit.

Test procedures are based on the special design characteristics of the hydraulic systems of hydraulic excavators and the backhoe part of backhoe loaders, and conditions of use.

1 Scope

This International Standard establishes uniform requirements and test procedures for boom lowering control devices fitted on boom lift cylinders to control the rate of drop in case of a hydraulic line failure or rupture.

2 Field of Application

This International Standard applies to boom control lowering devices on hydraulic excavators and the backhoe part of backhoe loaders, when used for lifting of loads.

3 References

ISO 6165, Earth-Moving machinery – Basic Types – Vocabulary.

4 Definitions

4.1 Boom Control System. Hydraulic control valve (s) (including pilot and slave valves) used for raising and lowering of the boom.

4.2 Rated Lift Capacity. Smaller of either the rated tipping capacity or the rated hydraulic lift capacity.

4.3 Lift point. One point as defined by the manufacturer for purpose of lifting. It is defined by lift point height and lift point radius.

4.4 Lift Point Height. Vertical distance from the lift point to the ground reference plane (GRP).

4.5 Lift Point Radius. Horizontal distance from the lift point to the axis of rotation.

5 Requirements for Lifting Loads

5.1 For hydraulic excavators and the backhoe part of backhoe loaders used in lifting operations, a controlled lowering device shall be provided which prevents uncontrolled lowering of the boom in case of a hydraulic line failure or rupture.

5.2 Such control devices shall operate automatically while raising, holding and lowering loads. In case of line rupture during down movement, the increase in the initial lowering speed shall be less than 200 mm/s, measured at the load, whatever the height of the fall. After the operator returns the control to neutral position, the drop rate of the load shall not exceed 10 mm/s, allowable for internal leakage in the system.

5.3 The operation of the boom control lowering device shall not detract from the normal response of the machine and shall not, at any time, endanger the stability of the machine.

5.4 A relief valve to protect the cylinder may be fitted between the cylinder and the control device.

5.5 In case of a failure of the boom control system, or after a boom line rupture, lowering of the load shall be possible without endangering person(s) or the stability of the machine.

5.6 except for tubes and fittings integrated into the cylinder assembly and supported at both ends, tubes and hoses shall not be used to connect:

(a) the lift cylinder to the control device;

(b) the lift cylinder to the relief valve when it is in parallel with the control device.

Tubes and fittings integrated into the cylinder assembly shall have a minimum burst pressure of four times the relief valve pressure for that part of the system.

5.7 Signal lines for testing device(s) and equalizing lines between lift cylinders are permissible, if rupture of one of those lines results in oil leakage of not more than 10 /min for each cylinder at approximately 40 to 60 degrees C oil temperature at the specified operating pressure.

6 Test Method

6.1 Apparatus

6.1.1 Stop Watch

6.1.2 Measuring Tape or Scale

6.1.3 Thermometer, measuring from 0 to 100 degrees C.

6.1.4. Measuring container, of 2 1 capacity of flowmeter.

6.1.5 Collecting container, for hydraulic oil or alternatively oil return line to tank.

6.1.6 Test load, a mass (50 +/- 10) % of the rated lift capacity at a specific lift point radius.

NOTE – Test methods ensuring equal results may be used, for example, a level size near a vertical wall to which a paper is pinned to record the load displacement in the tube or hose rupture simulation test, where the load is fitted with a stylus.

6.2 Preparation for Test

6.2.1 A failure-simulating device shall be installed in any connecting line the failure of which could cause the boom to lower. The tube for testing shall not increase the resistance of the connecting line.

Examples of such installations are:

(a) in the line between boom lift cylinder and control valve as shown in figure 1,

(b) in the signal line between boom lift cylinder and testing device as shown in figure 2,

(c) in the equalizing line between boom lift cylinders as shown in figure 3.

6.2.2 The complete hydraulic system shall be operated until the hydraulic oil temperature in the oil reservoir is approximately 40 to 50 degrees C. The hydraulic fluid shall be the type and grade specified by the manufacturer.

6.3 Testing of Control device

6.3.1 The test load shall be at the lift point radius which results in a moment equal to (50 +/- 10) % of the moment developed by the rated lift capacity at a specific lift point radius.

6.3.2 The functions of boom raise and lower shall be smooth and at a reduced speed of max. 200 mm/s, measured at the test load.

6.3.3 The load shall be lowered and set down after each test in accordance with 5.5.

6.4 Test of Holding position

6.4.1 The test load shall be raised approximately 1 m above ground level, with the control valve(s) in neutral position.

6.4.2 The failure-simulating valve between lift cylinders and control valve shall be opened.

6.4.3 The total drop of the load during the initial 10 shall be measured. It shall not exceed 100 mm.

6.5 Testing During Raise Function

6.5.1 The test load shall be lifted smoothly and continuously without shock (see 6.3.2).

6.5.2 The failure-simulating valve between the lift cylinder(s) and the control valve shall be opened.

6.5.3 The total drop of the load during the initial 10 shall be measured. It shall not exceed 100 mm.

6.6 Test During Lowering Function

6.6.1 The test load shall be lowered smoothly and continuously without shock (see 6.3.2).

6.6.2 The failure-simulating device between the lift cylinder(s) and the control valve shall be opened.

6.6.3 The increase in the lowering speed of the test load shall be less than 100% increase of the initial speed. After the control is moved to the neutral position, the device shall be able to limit boom movement so that the total drop of the load during the initial 10 of the test does not exceed 100 mm.

6.7 Testing of Equalizing Lines or Signal Lines

6.7.1 Testing shall be performed without load.

6.7.2 The boom shall be raised to its maximum lift height, and the control valve kept in the "lift" position.

6.7.3 The failure-simulating device shall be opened.

6.7.4 The oil leakage per cylinder shall not exceed 10 1/min.

Ref: Backhoe/Loader 4WD 11-12



**Invitation For Bid (IFB)
#TAC528D Backhoes
Issued: October 20, 2011
City of Tulsa**

**City of Tulsa,
Oklahoma**
Page 46 of 46

**EXHIBIT A
BID FORM INCLUDING DELIVERY AND PRICING**

1. Delivery. If your Bid is accepted and a contract is executed, state the number of days you need to deliver the Goods and/or to begin providing Services:

You must be able to deliver the Goods and/or Services as specified in your Bid. Failure to do so may result in City terminating your contract or canceling the Purchase Order, pursuing collection under any performance bond, as well as seeking any other damages to which it may be entitled in law or in equity.

2. Pricing

Item	Description (See Technical Specifications for details)	QTY (Estimated*)	Unit Cost	Extended Cost
1	2 WHEEL DRIVE BACKHOE including 24" bucket	8		
1a	EXTENDED WARRANTY FOR AN ADDITIONAL 4 YEARS/ 4,000 HOURS, FOR A TOTAL OF 5 YEARS, 5,000 HOURS.	8		
1b	PREVENTIVE MAINTENANCE FOR A TOTAL OF 5 YEARS OR 5,000 HOURS	8		
2	4 WHEEL DRIVE BACKHOE including 24" bucket	4		
2a	EXTENDED WARRANTY FOR AN ADDITIONAL 4 YEARS/ 4,000 HOURS, FOR A TOTAL OF 5 YEARS, 5,000 HOURS.	4		
2b	PREVENTIVE MAINTENANCE FOR A TOTAL OF 5 YEARS OR 5,000 HOURS	4		
	Additional options to fit either the 2WD or 4WD units			
3	OPTION 1A, 36" BUCKET	4		
4	OPTION 1B, 24" MULTI PURPOSE POWER GRIP CLAM SHELL STYLE BUCKET	4		
TOTAL COST NOT TO EXCEED: (All costs must be included or your Bid will be disqualified)			\$ _____	

* Quantities will vary from year to year

Bidder's Company Name _____

Authorized Signature Here ► _____

Printed Name: _____

RETURN THIS ENTIRE BID PACKET